

SH...A Shaft Supporter

Material : Aluminum alloy

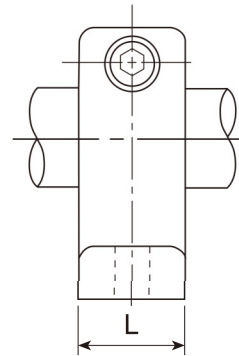
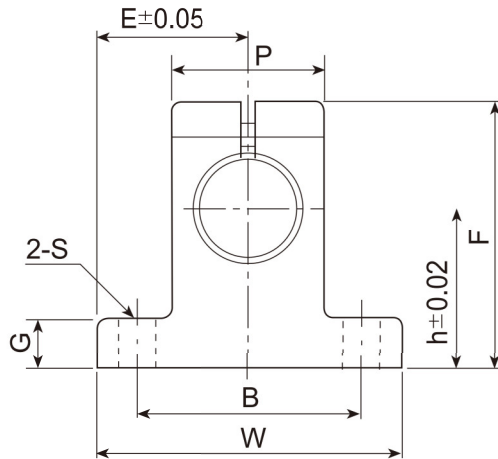
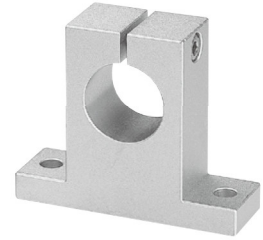

unit : mm

Model No.	Nominal shaft diameter	Main dimensions									Clamping bolt	Mounting bolt	Weight g
		h	E	W	L	F	G	P	B	S			
SH 8A	8	20	21	42	14	32.8	6	18	32	5.5	M4	M5	24
SH10A	10	20	21	42	14	32.8	6	18	32	5.5	M4	M5	24
SH12A	12	23	21	42	14	37.5	6	20	32	5.5	M4	M5	30
SH13A	13	23	21	42	14	37.5	6	20	32	5.5	M4	M5	30
SH16A	16	27	24	48	16	44	8	25	38	5.5	M4	M5	40
SH20A	20	31	30	60	20	51	10	30	45	6.6	M5	M6	70
SH25A	25	35	35	70	24	60	12	38	56	6.6	M6	M6	130
SH30A	30	42	42	84	28	70	12	44	64	9	M6	M8	180
SH35A	35	50	49	98	32	82	15	50	74	11	M8	M10	270
SH40A	40	60	57	114	36	96	15	60	90	11	M8	M10	420
SH50A	50	70	63	126	40	120	18	74	100	14	M12	M12	750
SH60A	60	80	74	148	45	136	18	90	120	14	M12	M12	1,100