

## MFL-C Flex couplings

- **Body material** : Aluminum alloy
- **Buffer material** : Nylon
- **Surface Treatment** : Anodizing standard white

■ **Features**

- High rigid
- High insulation
- Handy assembly
- Larger eccentricity and error of angle deviation allowable
- **Fixed mode** : Clamp type

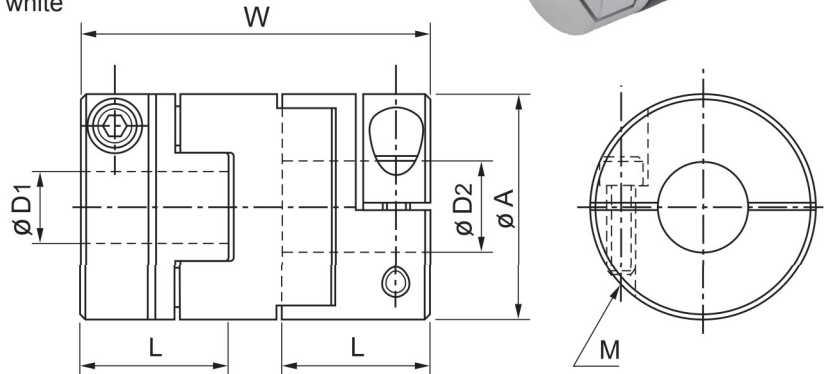

### DIMENSION

unit:mm

Product No	A	L	W	Stock Bores D1xD2 (H8)		M
				Min D1	Max D2	
MFL-16C	16	13	29	5	6	M2.5
MFL-20C	20	14	33	6	8	M2.5
MFL-25C	25	17	39	6	10	M3
MFL-32C	32	19	45	8	14	M4
MFL-40C	40	23	50	12	16	M5
MFL-50C	50	27	58	14	20	M6

### SPECIFICATIONS

\*Max. Bore Moment of Inertia

\*\*Max. Bore Mass

Product No	Rated Torque (N.m)	Max. Torque (N.m)	Max. Rotational Frequency (min <sup>-1</sup> )	Moment* of Inertia (kg.m <sup>2</sup> )	Error of Eccentricity (mm)	Errors of Angularity (°)	Mass** (g)
MFL-16C	0.7	1.4	9500	5.0X10 <sup>-7</sup>	1.0	3°	11.5
MFL-20C	1.2	2.4	7600	1.3X10 <sup>-6</sup>	1.5	3°	19
MFL-25C	2.0	4.0	6100	3.9X10 <sup>-6</sup>	2.0	3°	36
MFL-32C	4.5	9.0	4800	1.2X10 <sup>-5</sup>	2.5	3°	68
MFL-40C	9.0	18.0	3800	3.5X10 <sup>-5</sup>	3.0	3°	130
MFL-50C	18.0	36.0	3100	1.0X10 <sup>-4</sup>	3.5	3°	230

■ **When Ordering**

When Placing an order, make sure to include product No. and stock bores (both sides) of product.

MFL-25C -φ8 – φ10      Product No :    D1   D2