

## LMC-C LMCL-C

Anticorrosive Linear Guide  
Linear Block : Linear ball bearing type

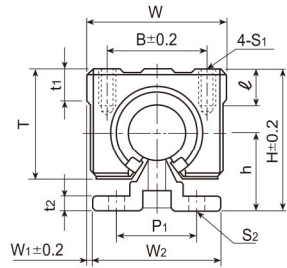

**LMC-C**  
LMC-C12 ~ LMC-C40

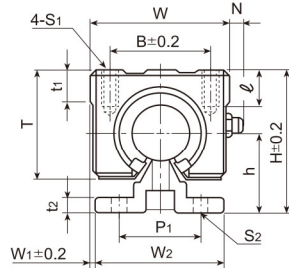

**LMCL-C**  
(Long Type)  
LMCL-C12 ~ LMCL-C30

| Model No.       | Shaft diameter | Dimensions of assembly |      |                |    | Dimensions of block |    |     |                |    |                |    |   |
|-----------------|----------------|------------------------|------|----------------|----|---------------------|----|-----|----------------|----|----------------|----|---|
|                 |                | H                      | h    | W <sub>1</sub> | W  | L <sub>1</sub>      | B  | C   | t <sub>1</sub> | ℓ  | S <sub>1</sub> | T  | N |
| <b>LMC-C12</b>  | 12             | 34.5                   | 19.5 | 2              | 36 | 34                  | 26 | 24  | 7              | 10 | M5             | 24 | — |
| <b>LMCL-C12</b> |                |                        |      |                |    | 68                  |    | 45  |                |    |                |    | 8 |
| <b>LMC-C16</b>  | 16             | 45                     | 25   | 2.5            | 45 | 45                  | 32 | 30  | 9              | 12 | M5             | 33 | — |
| <b>LMCL-C16</b> |                |                        |      |                |    | 85                  |    | 60  |                |    |                |    | 8 |
| <b>LMC-C20</b>  | 20             | 50                     | 27   | 1.5            | 48 | 50                  | 35 | 35  | 11             | 12 | M6             | 39 | — |
| <b>LMCL-C20</b> |                |                        |      |                |    | 96                  |    | 70  |                |    |                |    | 8 |
| <b>LMC-C25</b>  | 25             | 60                     | 33   | 2.5            | 60 | 65                  | 40 | 40  | 14             | 12 | M6             | 47 | — |
| <b>LMCL-C25</b> |                |                        |      |                |    | 130                 |    | 100 |                |    |                |    | 8 |
| <b>LMC-C30</b>  | 30             | 70                     | 37   | 5              | 70 | 70                  | 50 | 50  | 15             | 18 | M8             | 56 | — |
| <b>LMCL-C30</b> |                |                        |      |                |    | 140                 |    | 110 |                |    |                |    | 8 |
| <b>LMC-C40</b>  | 40             | 90                     | 48   | 7.5            | 90 | 90                  | 65 | 65  | 20             | 20 | M10            | 72 | — |

Example of identification number:

**LMC-C25-B2-2400**  
① ② ③ ④

- ① Model No: LMC-C, LMCL-C
- ② Shaft Diameter (mm): Shaft : Hardened(HRC62±2)ground and chromium plated  
Shaft type: SCFB
- ③ Number of blocks per track rail: B1: 1 Block B2: 2 Blocks B3: 3 Blocks,...
- ④ Length of track rail: (2400mm)

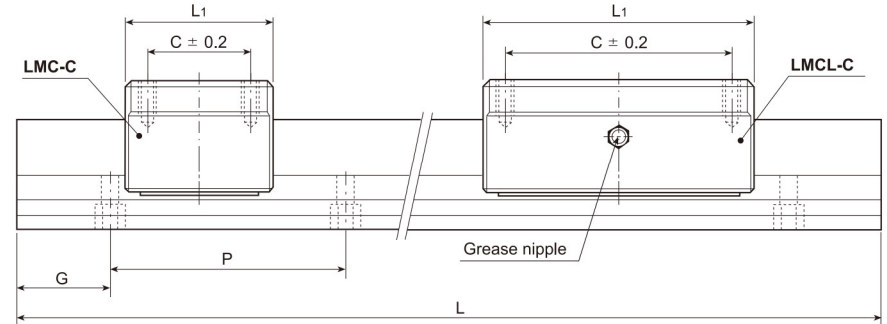

unit : mm

| Dimensions of track rail |                |                |     |                |         | Basic dynamic load rating | Basic static load rating | Model No.       |
|--------------------------|----------------|----------------|-----|----------------|---------|---------------------------|--------------------------|-----------------|
| W <sub>2</sub>           | P <sub>1</sub> | t <sub>2</sub> | P   | S <sub>2</sub> | L (max) | C (kgf)                   | Co (kgf)                 |                 |
| 32                       | 23             | 4              | 100 | 4.5            | 4,000   | 42                        | 61                       | <b>LMC-C12</b>  |
|                          |                |                |     |                |         | 84                        | 122                      | <b>LMCL-C12</b> |
| 40                       | 30             | 5              | 150 | 5.5            | 4,000   | 79                        | 120                      | <b>LMC-C16</b>  |
|                          |                |                |     |                |         | 158                       | 240                      | <b>LMCL-C16</b> |
| 45                       | 30             | 5              | 150 | 5.5            | 4,000   | 90                        | 140                      | <b>LMC-C20</b>  |
|                          |                |                |     |                |         | 180                       | 280                      | <b>LMCL-C20</b> |
| 55                       | 35             | 6              | 200 | 6.5            | 4,000   | 100                       | 160                      | <b>LMC-C25</b>  |
|                          |                |                |     |                |         | 200                       | 320                      | <b>LMCL-C25</b> |
| 60                       | 40             | 7              | 200 | 6.5            | 4,000   | 160                       | 280                      | <b>LMC-C30</b>  |
|                          |                |                |     |                |         | 320                       | 560                      | <b>LMCL-C30</b> |
| 75                       | 55             | 9              | 300 | 9              | 4,000   | 220                       | 410                      | <b>LMC-C40</b>  |