

Shaft Type Linear Guides

LMC Open Type Linear Block (Linear Ball Bearing Type)

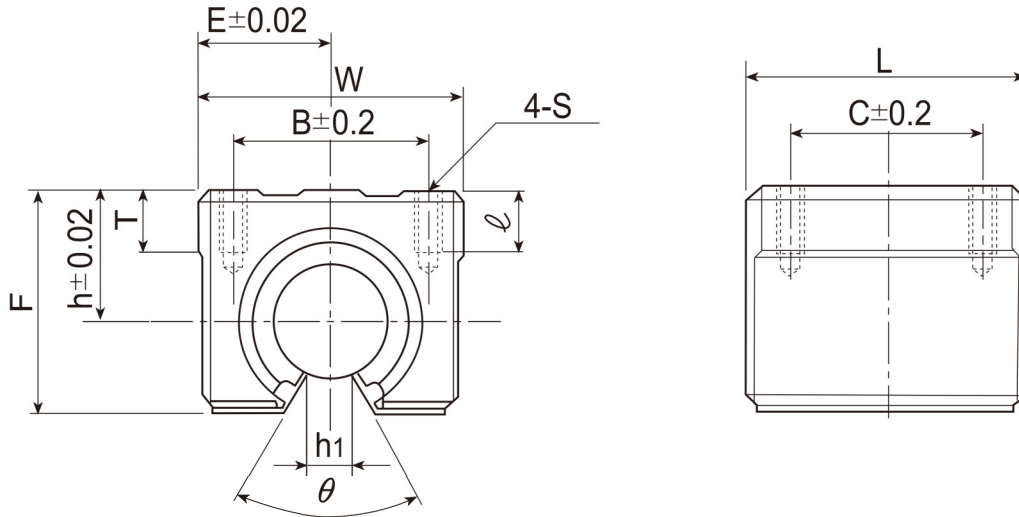

unit : mm

Model No.	Shaft diameter	Main dimensions								Mounting dimension				Linear ball bearing			Weight g
		h	E	W	L	F	T	h1	θ	B	C	S	ℓ	※ Linear ball bearing No.	Basic dynamic load rating C (kgf)	Basic static load rating Co(kgf)	
LMC12UU	12	15	18	36	34	24	7	8	80°	26	24	M5	10	LM12UU OP	42	61	65
LMC16UU	16	20	22.5	45	45	33	9	10	80°	32	30	M5	12	LM16UU OP	79	120	150
LMC20UU	20	23	24	48	50	39	11	10	60°	35	35	M6	12	LM20UU OP	90	140	200
LMC25UU	25	27	30	60	65	47	14	11.5	50°	40	40	M6	12	LM25UU OP	100	160	450
LMC30UU	30	33	35	70	70	56	15	14	50°	50	50	M8	18	LM30UU OP	160	280	630
LMC40UU	40	42	45	90	90	72	20	19	50°	65	65	M10	20	LM40UU OP	220	410	1,330